

4WD DYNAMOMETER AIR AND WIRING SCHEMATIC

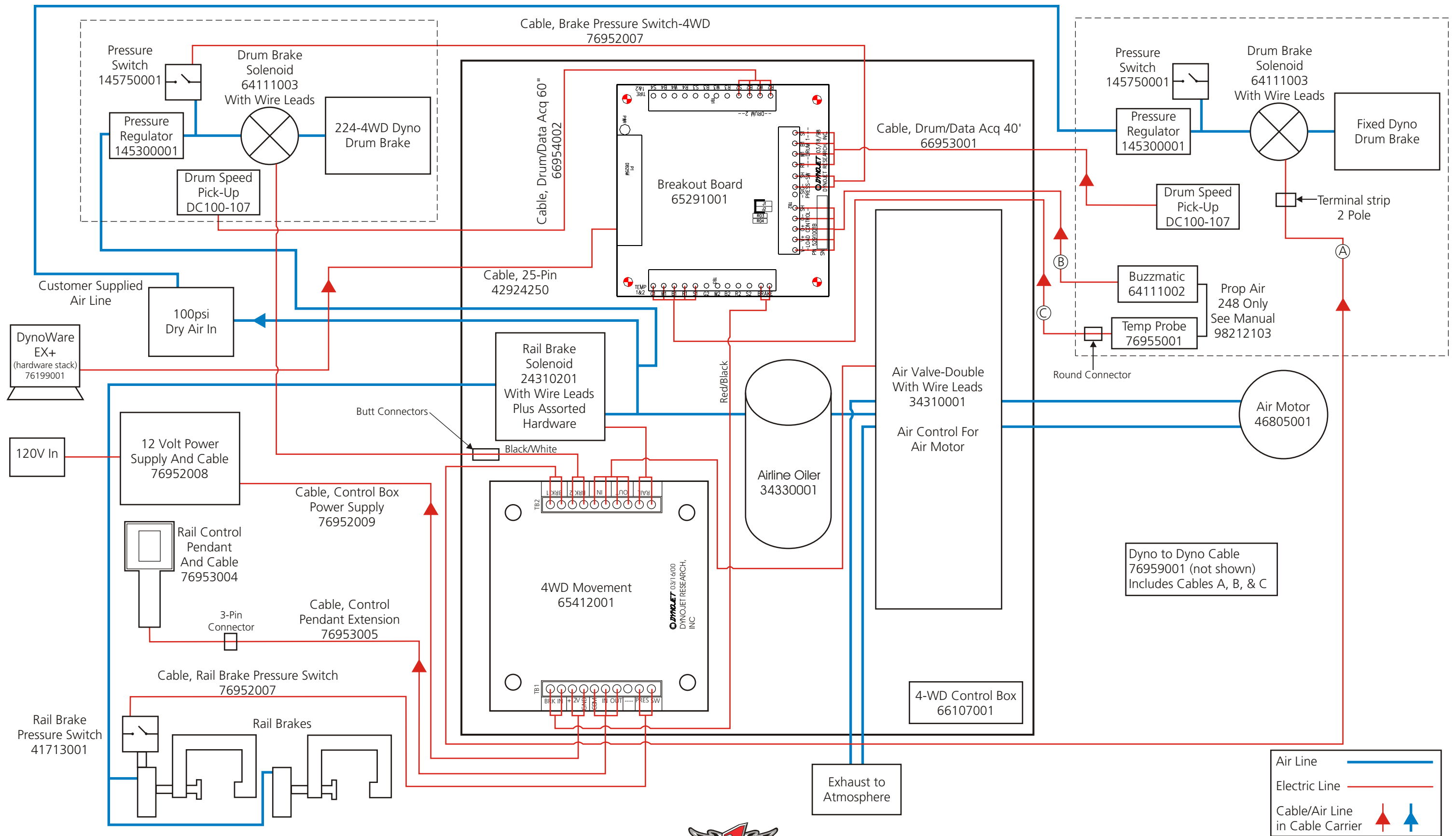

4WD MOVEMENT BOARD TEST

Use a multi-meter to read each terminal and determine the voltage that should be present as listed on this sheet.
The red probe is always placed on the first number.

red probe
on first
number

black
probe

TB2: Top Row of Terminals on PCB Reading Left to Right

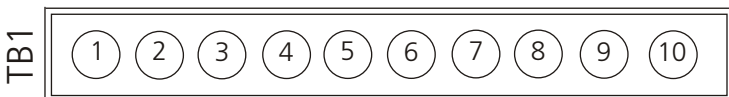
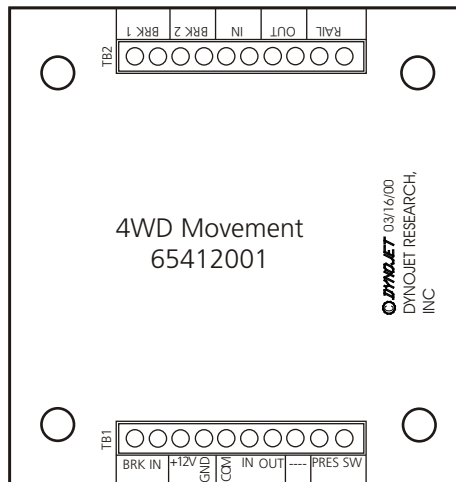
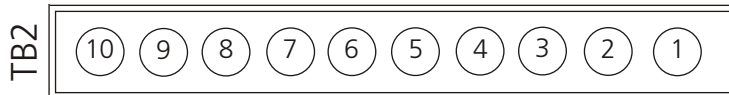

TB1: Bottom Row of Terminals on PCB Reading Left to Right

10—9 brake signal to cable
brake off +12 VDC
brake on 0 VDC

8—7 brake signal to solenoid
brake off +12 VDC
brake on 0 VDC

6—5 11.57 VDC when IN switch on remote is pushed

4—3 11.57 VDC when OUT switch on remote is pushed

2—1 10.68 VDC when either IN/OUT switch is pushed on remote

1—2 brake signal from Breakout board
brake off +12 VDC
brake on 0 VDC

3—4 12 VDC in from P/S

5—4 when brake is applied, reads 12 VDC

6—4 with brake applied, with the remote switch pressed to IN, reads 12 VDC

7—4 with brake applied, with the remote switch pressed to OUT, reads 12 VDC

8— not wired

For this test, you will check for continuity:

9—10 air pressure switch: sufficient air pressure equals continuity, insufficient air pressure equals no continuity

