

Thank you for purchasing this Dynojet kit. This kit has been developed for a motorcycle which is set to the parameters listed at the right in the "Stage" description. If your motorcycle does not meet any of these parameters please check with Dynojet before installation. For technical assistance contact your Dynojet distributor or call Dynojet U.S.A. (800)-992-4993

2191 Mendenhall Dr. Suite 105  
 North Las Vegas, NV 89031  
 TEL: 702-399-1423  
 FAX: 702-399-1431  
 8am-5pm Pacific Time  
 Monday through Friday

Website Address  
<http://www.dynojet.com>

The manufacturer and seller make no warranties express or implied which extend beyond the description of the goods contained herein. Any description of this product is for the purpose of identifying it and shall not be deemed to create an express warranty.



**1153HA.001**

High Altitude Only

*1993-95 Honda CBR1000*

**Stage 1**

For mildly tuned machines using the stock airbox, with stock or K&N filter. May also be used with a good aftermarket exhaust system  
 K&N filter #HA-1087

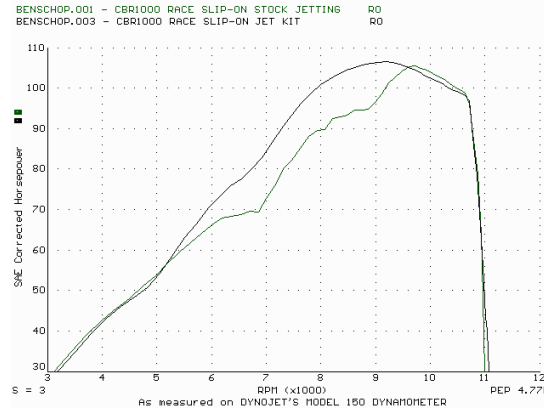

*This graph shows a typical gain with a Dynojet jet kit.*

# WARNING

**NO SMOKING!  
 NO OPEN FLAME!  
 WHILE INSTALLING  
 YOUR DYNOJET KIT**

## Parts List

4	Main Jets	DJ110
4	Main Jets	DJ114
4	Fuel Needles	DNO110
4	Adjusting Washers	DW0001
4	E-Clips	DE0001
4	Slide Springs	DSP007
1	Idle Adjustment Tool	DT009

## STAGE ONE INSTRUCTIONS

**DYNOJET**  
1153HA.001

1. Remove the vacuum slide from the carbs. Remove the spring from slide. Thread one of the slide cover screws into the center of the needle retainer (Fig. A) and pull up gently. Remove the stock needles & spacers, noting the order of assembly (Fig. B)

2. Install the Dynojet needles on groove #1, using all stock spacers (Fig. B). Install the Dynojet washers above the E-clip. Install the stock spring retainers with the Dynojet springs.

3. Remove the stock main jets and replace with Dynojet main jets provided. If you are running the stock exhaust use the DJ110 main jets, if you are running an aftermarket header or slip-on with a high flowing baffle, use the DJ114 main jets. Be sure that the jets you are changing are the main jets.

4. Locate the fuel mixture tab (Fig. C) Using the tool supplied, carefully turn mixture tabs clockwise until they seat, turn out 2 turns or where you find your best idle.

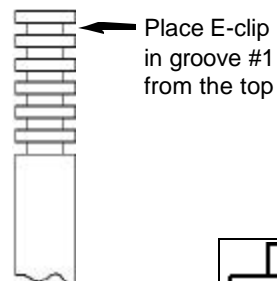

Fig. C

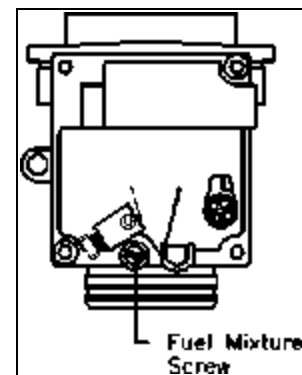

Fig. A

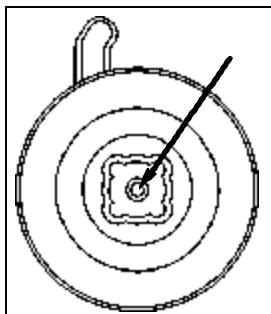

Fig. B

