

Thank you for purchasing this Dynojet kit. This kit has been developed for a motorcycle which is set to the parameters listed at the right in the "Stage" description. If your motorcycle does not meet any of these parameters please check with Dynojet before installation. For technical assistance contact your Dynojet distributor or call Dynojet U.S.A. (800)-992-4993

2191 Mendenhall Dr. Suite 105
 North Las Vegas, NV 89031
 TEL: 702-399-1423
 FAX: 702-399-1431
 8am-5pm Pacific Time
 Monday through Friday

Website Address
<http://www.dynojet.com>

The manufacturer and seller make no warranties express or implied which extend beyond the description of the goods contained herein. Any description of this product is for the purpose of identifying it and shall not be deemed to create an express warranty.



2154HA.002

High Altitude Only

1993-95 Kawasaki ZX7

Stage 1

For mildly tuned machines using the stock airbox, with stock or K&N filter. May also be used with a good aftermarket exhaust system
 K&N filter #KA-0007

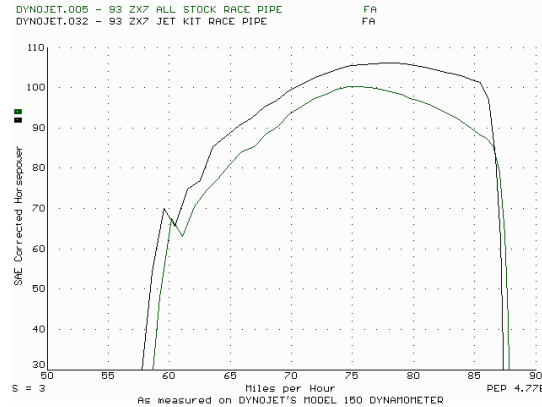

This graph shows a typical gain with a Dynojet jet kit.

WARNING

**NO SMOKING!
 NO OPEN FLAME!
 WHILE INSTALLING
 YOUR DYNOJET KIT**

2	Main Jets	DJ116
2	Main Jets	DJ120
2	Main Jets	DJ124
4	Fuel Needles	DNO119
4	Main Air Plugs	DCO200
1	Tool	DT001
1	Glue	DA0001
8	Adjusting Washers	DW0001
4	E-Clips	DE0001
1	Slide Drill	DD #40
1	Screw	DS0001
1	Plug Drill	DD #5/32

STAGE ONE INSTRUCTIONS

1. Remove vacuum slides from carbs. Remove stock needles and spacers, noting order of assembly (Fig.A)
2. Install Dynojet needles on groove #3 from the top. Use all stock spacers. Install the small Dynojet washers above the E-clip (2 per needle). After installing the slides in carbs be sure to check slide movement manually before air box installation.
3. Remove the stock main jets and replace with Dynojet mains provided. If you are running the stock exhaust install the DJ116 main jets in the outside two carburetors and the DJ120 main jets in the inside two carburetors. If you are running an aftermarket exhaust or slip-on with high flowing baffle use the DJ120 main jets in the outside two carburetors and the DJ124 main jets in the inside two carburetors. Be sure that the jets you are changing are the main jets.
4. Locate the main air passage (Fig. C). With the flat end facing into the carb, install the main air plugs provided (DCO200). Use the tool provided (DT001) to tap lightly in place. With the glue provided **lightly** touch a dab on the outer edge of the air corrector. Allow glue to dry.
5. Locate the fuel mixture plug (Fig. D). If you see a screw head at Fig. D then proceed to the adjusting procedure. With the DD #5/32 drill bit provided carefully drill through the plug. **NOTE:** The mixture screw is directly underneath this plug, be ready to pull back on the drill the instant you break through. Use screw provided to secure and remove this plug. Carefully turn the mixture screws clockwise until lightly seated, then back out 2-1/2 turns.

Note: Float level must be set at 14.5MM in order for this kit to function correctly.

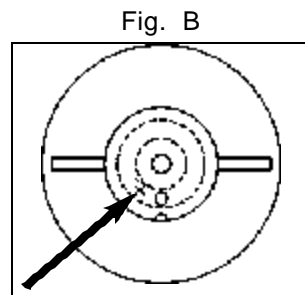
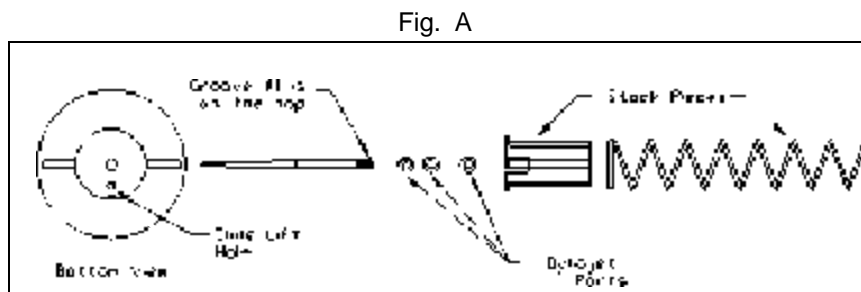

DYNOJET
2154HA.002

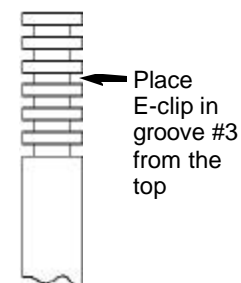

Fig. D

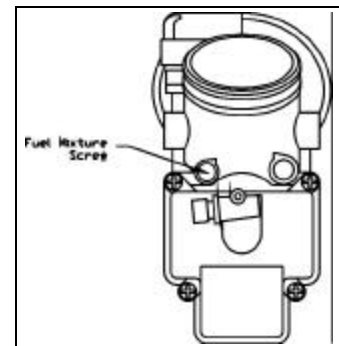

Fig. C

