

Thank you for purchasing this Dynojet kit. This kit has been developed for a motorcycle which is set to the parameters listed at the right in the "Stage" description. If your motorcycle does not meet any of these parameters please check with Dynojet before installation. For technical assistance contact your Dynojet distributor or call Dynojet U.S.A. (800)-992-4993

2191 Mendenhall Dr. Suite 105
 North Las Vegas, NV 89031
 TEL: 702-399-1423
 FAX: 702-399-1431
 8am-5pm Pacific Time
 Monday through Friday

Website Address
<http://www.dynojet.com>

The manufacturer and seller make no warranties express or implied which extend beyond the description of the goods contained herein. Any description of this product is for the purpose of identifying it and shall not be deemed to create an express warranty.



3144CA.002

California Models Only

1995-98 Suzuki GSXR1100W

Stage 1

For mildly tuned machines using the stock airbox, with stock or K&N filter. May also be used with a good aftermarket exhaust system
 K&N filter #SU-7593

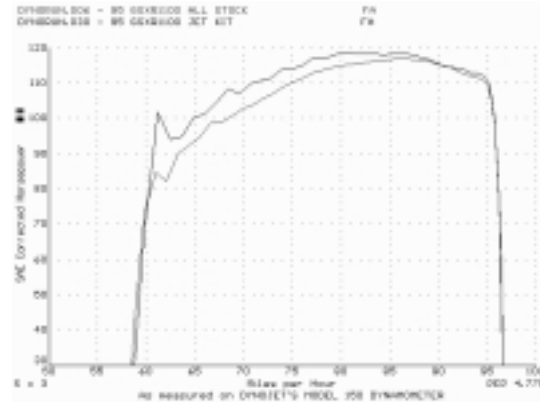

This graph shows a typical gain with a Dynojet jet kit.

WARNING

**NO SMOKING!
 NO OPEN FLAME!
 WHILE INSTALLING
 YOUR DYNOJET KIT**

Parts List		
4	Main Jets	DJ112
4	Main Jets	DJ116
4	Main Jets	DJ120
4	Fuel Needles	DNO362
4	Slide Springs	DSP007
4	Adjusting Washers	DW0001
4	E-Clips	DE0001
4	Emulsion Tubes	DET002
4	Pilot Air Correctors	DCO302
1	Glue	DA0001
1	Plug Drill	DD #5/32
1	Screw	DS0001

STAGE ONE INSTRUCTIONS

1. Remove the vacuum slides from the carbs. Remove the stock needles and spacers, noting the order of assembly (Fig. A).
2. Remove the stock main jets. Tap lightly on the emulsion tubes to push them into the carb venturi and remove. Install the Dynojet emulsion tubes (DET002) in place of the stock emulsion tubes (Fig. B).
3. Install the Dynojet main jets provided. If you are running the stock exhaust install the DJ116 main jets. If you are running an aftermarket exhaust or slip-on with a high flowing baffle, use the DJ120 main jets. Be sure that the jet you are changing is the main jet.
4. Install the Dynojet needles on groove #3. Use all stock spacers (Fig. A). Install the small Dynojet washers above the e-clip. Install the Dynojet slide springs (DSP007) in place of the stock slide springs. After installing the slides in the carbs be sure to check slide movement manually.
5. Locate the pilot air jets in the bell mouth of the carbs (Fig. C). Install the pilot air jet correctors (DCO302) in the pilot air jets. Use a light dab of glue to secure corrector in place. Make sure not to get glue in the air corrector holes.
6. Locate the fuel mixture plug (Fig. D). If you see a screw head at Fig. D proceed to adjusting procedure. With the DD #5/32 drill bit provided carefully drill through the plugs. **NOTE:** The mixture screw is directly underneath this plug, be ready to pull back on the drill the instant you break through. Use screw provided to secure and remove this plug. Carefully turn mixture screws clockwise until lightly seated, then back out 1-1/2 turns.

DYNOJET

3144CA.002

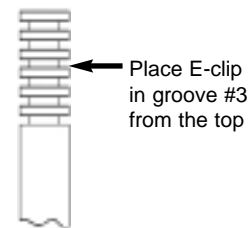

Fig. D

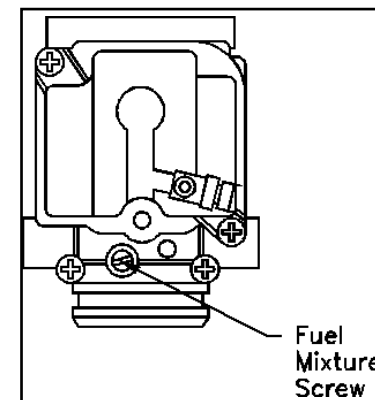

Fig. A

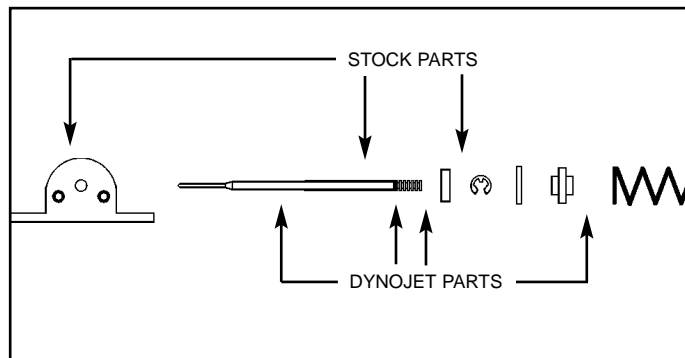

Fig. B

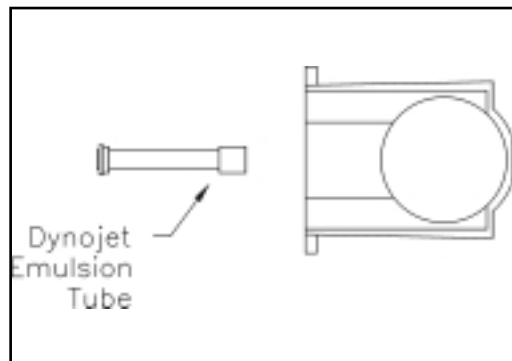

Fig. C

