

Thank you for purchasing this Dynojet kit. This kit has been developed for a motorcycle which is set to the parameters listed at the right in the "Stage" description. If your motorcycle does not meet any of these parameters please check with Dynojet before installation. For technical assistance contact your Dynojet distributor or call Dynojet U.S.A. (800)-992-4993

2191 Mendenhall Dr. Suite 105
 North Las Vegas, NV 89031
 TEL: 702-399-1423
 FAX: 702-399-1431
 8am-5pm Pacific Time
 Monday through Friday

Website Address
<http://www.dynojet.com>

The manufacturer and seller make no warranties express or implied which extend beyond the description of the goods contained herein. Any description of this product is for the purpose of identifying it and shall not be deemed to create an express warranty.



3315.003

U.S Models Only

1980-85 Suzuki GS750E, ES

Stage 3

For mildly tuned machines using individual filters or velocity stacks. May also be used with a good aftermarket exhaust system. K&N filter #RC-9084

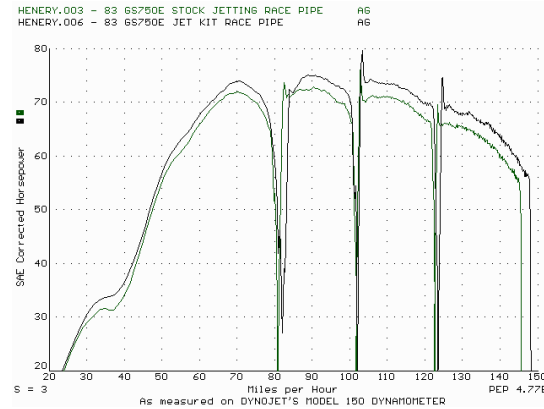

This graph shows a typical gain with a Dynojet jet kit.

WARNING

**NO SMOKING!
 NO OPEN FLAME!
 WHILE INSTALLING
 YOUR DYNOJET KIT**

Parts List

4	Main Jets	DJ124
4	Main Jets	DJ130
4	Main Air Correctors	DCO302
4	Fuel Needles	DNT604
4	Adjusting Washers	DW0001
4	E-clips	DE0001
1	Tool	DT002
1	Glue	DA0001
1	Screw	DS0001
1	Slide Drill	DD #30
1	Plug Drill	DD #5/32

STAGE THREE INSTRUCTIONS

1. Remove the vacuum slide from the carbs. Remove the stock needles & spacers, noting the order of assembly. Using the slide drill provided (DD# 30) enlarge your slide lift hole. Do not drill the needle hole.

2. Install the Dynojet needles on groove #4, using all stock spacers. Install the Dynojet washers above the E-clip.

3. Remove the stock main jets and replace with Dynojet main jets provided. If you are running the stock exhaust use the DJ124 main jets, if you are running an aftermarket header or slip-on, use the DJ130 main jets. Be sure that the jets you are changing are the main jets.

4. Locate the main air jet passage (Fig. B). With the flat end facing into the carb, install the main air correctors provided (DCO302). Use the tool provided (DT002) to tap lightly in place. With the glue provided lightly touch a dab on the outer edge of the air corrector. Allow glue to dry.

5. Locate the fuel mixture plug (Fig. C), if you see a screw head, proceed to adjusting procedure. With the DD #5/32 drill bit provided, carefully drill thru the plugs. NOTE: the mixture screw is directly underneath this plug, be ready to pull back on the drill the instant you break thru. Use screw provided to secure and remove the plug. Carefully turn mixture screws clockwise until they seat, turn out 3 turns.

DYNOJET

3315.003

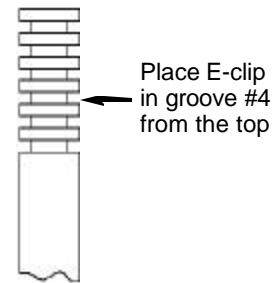

Fig. B

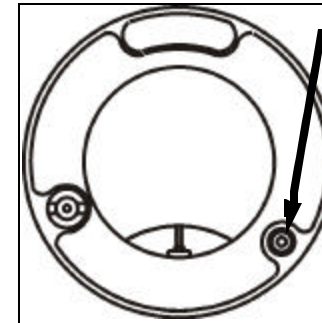

Fig. C

