

Thank you for purchasing this Dynojet kit. This kit has been developed for a motorcycle which is set to the parameters listed at the right in the "Stage" description. If your motorcycle does not meet any of these parameters please check with Dynojet before installation. For technical assistance contact your Dynojet distributor or call Dynojet U.S.A. (800)-992-4993

2191 Mendenhall Dr. Suite 105
 North Las Vegas, NV 89031
 TEL: 702-399-1423
 FAX: 702-399-1431
 8am-5pm Pacific Time
 Monday through Friday

Website Address
<http://www.dynojet.com>

The manufacturer and seller make no warranties express or implied which extend beyond the description of the goods contained herein. Any description of this product is for the purpose of identifying it and shall not be deemed to create an express warranty.



4142HA.001

High Altitude Only

1994-96 Yamaha YZF600R

Stage 1

For mildly tuned machines using the stock airbox, with stock or K&N filter. May also be used with a good aftermarket exhaust system
 K&N filter #N/A

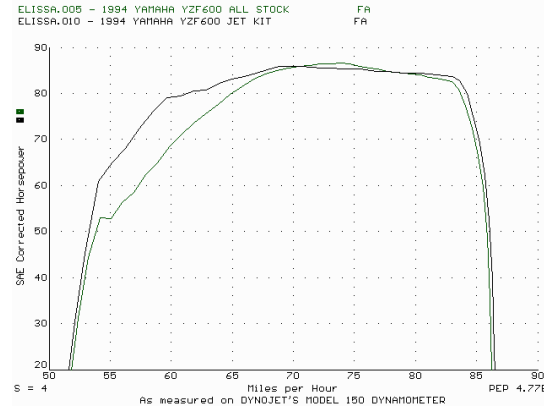

This graph shows a typical gain with a Dynojet jet kit.

WARNING

**NO SMOKING!
 NO OPEN FLAME!
 WHILE INSTALLING
 YOUR DYNOJET KIT**

Parts List

4	Main Jets	DJ096
4	Main Jets	DJ100
4	Fuel Needles	DNO368
1	Slide Drill	DD #42
8	Adjusting Washers	DW0001
4	E-Clips	DE0001
4	Main Air Correctors	DCO200
1	Tool	DT001
1	Plug Drill	DD #5/32
1	Screw	DS0001

STAGE ONE INSTRUCTIONS

DYNOJET
4142HA.001

1. Remove the vacuum slide from the carbs. Remove the stock needles & spacers, noting the order of assembly.
2. Using the DD #42 drill bit provided, drill an auxiliary lift hole in the position of the x in Fig. A. This modification is very important to the correct function of this kit.
3. Install the Dynojet needles on groove #3 from the top, using all stock spacers. Install the Dynojet washers (2 per needle) above the E-clip.
4. Remove the velocity stack plate and locate the main air jet passage (Fig. B). With the flat end facing into the carb, install the main air correctors provided (DCO200). Use the tool provided (DT001) to tap lightly in place.
5. Remove the stock main jets and replace with the Dynojet main jets provided. If you are running the stock exhaust use the DJ096 main jets, if you are running an aftermarket header or slip-on with high flowing baffle, use the DJ100 main jets. Be sure that the jets you are changing are the main jets.
6. Locate the fuel mixture plug (Fig. C), if you see a screw head, proceed to adjusting procedure. With the DD #5/32 drill bit provided, carefully drill thru the plugs. NOTE: the mixture screw is directly underneath this plug, be ready to pull back on the drill the instant you break thru. Use screw provided to secure and remove the plug. Carefully turn mixture screws clockwise until they seat, turn out 2 turns.

Fig. A

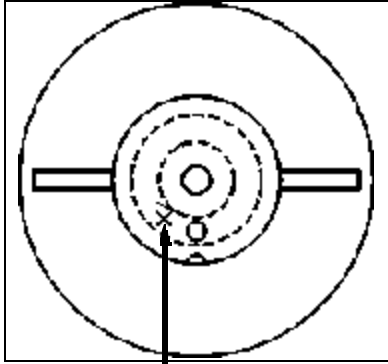

Auxiliary Slide Lift Hole Location

Fig. B

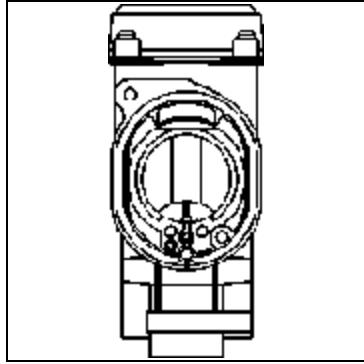

Fig. C

