

Thank you for purchasing this Dynojet kit. This kit has been developed for a motorcycle which is set to the parameters listed at the right in the "Stage" description. If your motorcycle does not meet any of these parameters please check with Dynojet before installation. For technical assistance contact your Dynojet distributor or call Dynojet U.S.A. (800)-992-4993

2191 Mendenhall Dr. Suite 105
 North Las Vegas, NV 89031
 TEL: 702-399-1423
 FAX: 702-399-1431
 8am-5pm Pacific Time
 Monday through Friday

Website Address
<http://www.dynojet.com>

The manufacturer and seller make no warranties express or implied which extend beyond the description of the goods contained herein. Any description of this product is for the purpose of identifying it and shall not be deemed to create an express warranty.



E2155F.001

French Models Only

1994-97 Kawasaki ZXR900

Stage 1

For mildly tuned machines using the stock air-box, with stock or K&N filter. May also be used with a good aftermarket exhaust system
 K&N filter #KA-0011

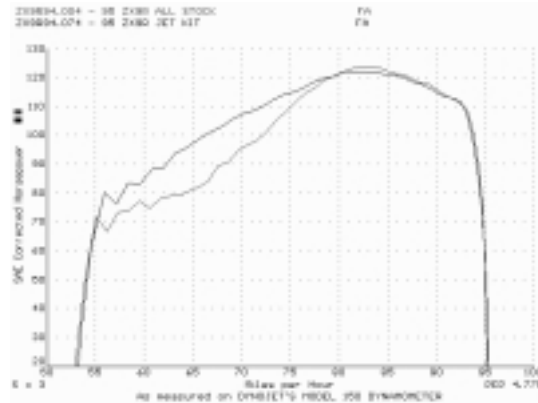

This graph shows a typical gain with a Dynojet jet kit.

WARNING

**NO SMOKING!
 NO OPEN FLAME!
 WHILE INSTALLING
 YOUR DYNOJET KIT**

Parts List

4	Main Jets	DJ180
4	Main Jets	DJ190
4	Main Jets	DJ200
4	Fuel Needles	DNO234
1	Slide Drill	DD #40
4	Slide Springs	DSP006
8	Adjustment Washers	DW0001
4	E-Clips	DE0001

STAGE ONE INSTRUCTIONS

1. Remove the vacuum slide from the carbs. Remove the stock needles & spacers, noting the order of assembly (Fig. A).
2. Using the slide drill (DD# 40) provided, drill an auxiliary lift hole in the position of the x in Fig. A. If you would rather not drill the extra hole that is fine, but you will not get as big as performance gains out of this kit.
3. Install the Dynojet needles on groove #4 from the top, using all stock spacers. Install the Dynojet washers (two for each needle) above the E-clip.
4. Install the Dynojet springs provided in place of the stock springs.
5. Remove the stock main jets and replace with Dynojet main jets provided. If you are running the stock exhaust use the DJ180 main jets, if you are running an aftermarket header or slip-on with high flowing baffle, use the DJ190 main jets. Be sure that the jets you are changing are the main jets.
6. Locate the Fuel Mixture Screws (Fig. C), Carefully turn the mixture screws clockwise until lightly seated, then turn back out until you find your best idle. Our base setting is 1-1/2 turns.

DYNOJET

E2155F.001

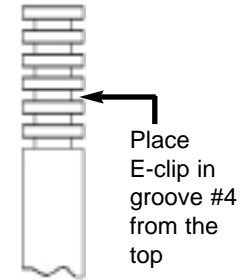

Fig. A

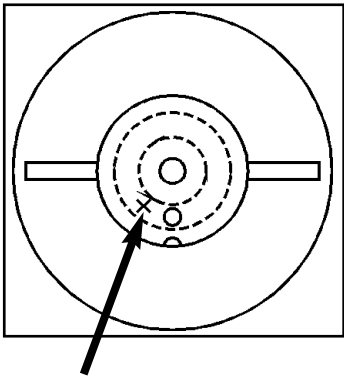

Fig. C

