

# Q121.001

## 2009-2012 Honda

### TRX400X

#### Stage 1&2

##### Stage 1

For mildly tuned machines using the stock airbox with stock or aftermarket filter. May also be used with a good aftermarket exhaust system.

##### Stage 2

For mildly tuned machines using the stock airbox with airbox lid removed, using stock or aftermarket filter. Should also be used with a good aftermarket exhaust system.

<b><i>Parts List</i></b>		
1	Main Jet	DJ134
1	Main Jet	DJ138
1	Main Jet	DJ142
1	Main Jet	DJ146
1	Main Jet	DJ150
1	Main Jet	DJ155
1	Main Jet	DJ160
1	Main Jet	DJ165
1	Main Jet	DJ170
1	Main Jet Adapter	DJA001
1	Fuel Needle	DNO190
1	Mixture Screw Tool	DT008
1	Adjusting Washer	DW0001
1	E-Clip	DE0001

## STAGE ONE INSTRUCTIONS

1. Remove top carb plate. Remove the slide lift arm screw and the two needle plate screws. Flip the linkage forward and remove the slide (Fig. A).
2. Install Dynojet needle on groove# 3 for applications below 5000 feet, groove #2 for above 5000 feet, using all stock spacers. Install the Dynojet washer above the E-clip.
3. Remove stock main jet. Replace with the Dynojet Main Jet Adapter (DJA001). Screw the Dynojet main jet provided into the Main Jet Adapter. If you are running the stock exhaust use the DJ142 below 3000 feet, DJ138 from 3000 to 6000 feet and DJ134 above 6000 feet. If you are running an aftermarket exhaust, use the DJ146 below 3000 feet, DJ142 from 3000 to 6000 feet and DJ138 above 6000 feet. Be sure that the jet you are changing is the main jet.
4. Locate the Fuel Mixture Screw (Fig.B). Use the tool provided (DT008) to adjust the mixture screw. Turn the mixture screw clockwise until it seats, then turn out 3.5 turns below 5000 feet or 3 above 5000 feet.

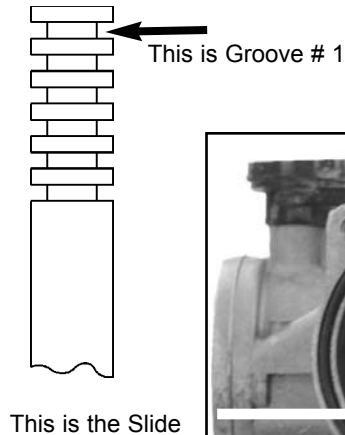
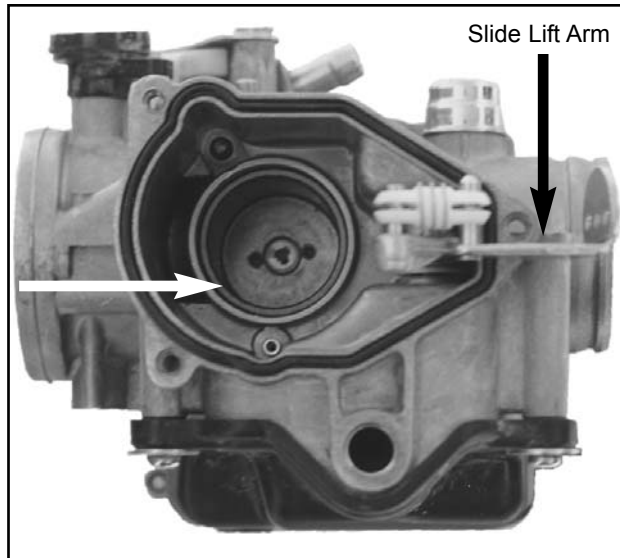

Fig.A



## STAGE TWO INSTRUCTIONS

Q121.001

1. Remove the airbox lid.
2. Remove top carb plate. Remove the slide lift arm screw and the two needle plate screws. Flip the linkage forward and remove the slide (Fig. A).
3. Install Dynojet needle on groove# 3 for applications below 5000 feet, groove #2 for above 5000 feet, using all stock spacers. Install the Dynojet washer above the E-clip.
4. Remove stock main jet. Replace with the Dynojet Main Jet Adapter (DJA001). Screw the Dynojet main jet provided into the Main Jet Adapter. If you are running the stock exhaust use the DJ165 below 3000 feet, DJ160 from 3000 to 6000 feet and DJ155 above 6000 feet. If you are running an aftermarket exhaust, use the DJ170 below 3000 feet, DJ165 from 3000 to 6000 feet and DJ160 above 6000 feet. Be sure that the jet you are changing is the main jet.
5. Locate the Fuel Mixture Screw (Fig.B). Use the tool provided (DT008) to adjust the mixture screw. Turn the mixture screw clockwise until it seats, then turn out 3.5 turns below 5000 feet or 3 above 5000 feet.

Fig.B

