

Q203.001
1991-2001 Kawasaki 300
Bayou
STAGE 1

For mildly tuned machines using the stock airbox, with stock or aftermarket filter. May also be used with a good aftermarket exhaust system. K&N Filter # KA-4093.

PARTS LIST		
1	Main Jet	DJ110
1	Main Jet	DJ114
1	Main Jet	DJ118
1	Fuel Needle	DNO368
1	Slide Drill	DD#32
2	Adjusting Washer	DW0001
1	E-Clip	DE0001

STAGE ONE INSTRUCTIONS

1. Remove vacuum slide from carb. Remove stock needle & spacers, noting order of assembly.
2. Drill slide lift hole with DD32 drill bit supplied.
3. Install Dynojet needle on groove# 4 for applications below 5000 feet, groove #3 for above 5000 feet, using all stock spacers. Install the Dynojet washers above the E-clip.
4. Remove stock main jet and replace with Dynojet main provided. Use the DJ118 below 3000 feet, DJ114 from 3000 to 6000 feet and DJ110 above 6000Feet. Be sure that the jet you are changing is the main jet.
5. Locate the Fuel Mixture Screw. Using a flat blade screwdriver, turn the mixture screw clockwise until it seats, then turn out 1 1/2 turns .

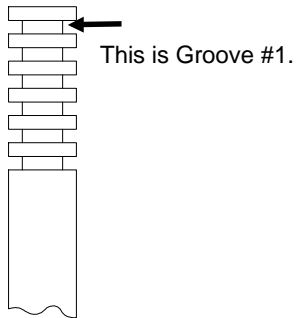
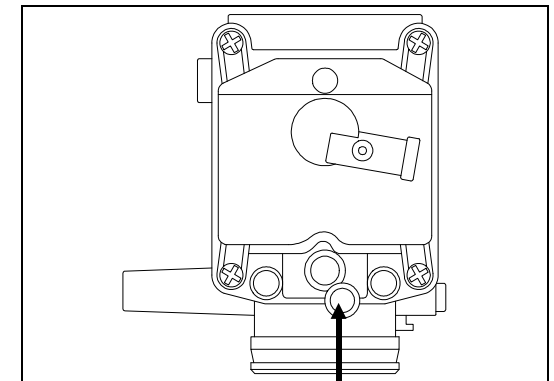
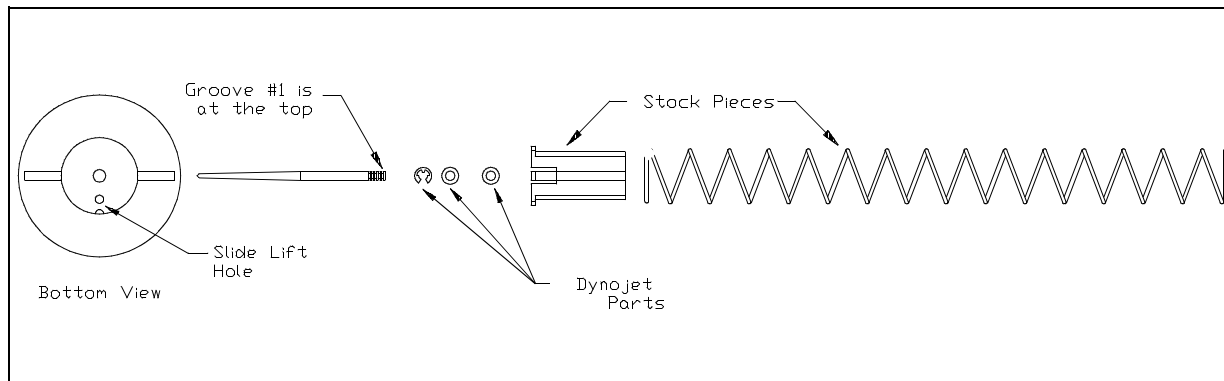

Fig. A

Fig. B



Fuel Mixture Screw